

Name (Print) _____
(Last) (First)

**ME 323 - Mechanics of Materials
Exam # 1**

Date: October 2, 2019 Time: 8:00 – 10:00 PM

Instructions:

Circle your instructor's name and your class meeting time.

Gonzalez	Kokini	Zhao	Pribe
11:30-12:20PM	12:30-1:20PM	2:30-3:20PM	4:30-5:20PM

The only authorized exam calculator is the TI-30XIIS or the TI-30Xa.

Begin each problem in the space provided on the examination sheets.

Work on **one side** of each sheet only, with only one problem on a sheet.

Please remember that for you to obtain maximum credit for a problem, you must present your solution clearly. Accordingly,

- coordinate systems must be clearly identified,
- free body diagrams must be shown,
- units must be stated,
- write down clarifying remarks,
- state your assumptions, etc.

If your solution cannot be followed, **it will be assumed that it is in error.**

When handing in the test, make sure that ALL SHEETS are in the correct sequential order.

Please review and sign the following statement:

Purdue Honor Pledge – “As a Boilermaker pursuing academic excellence, I pledge to be honest and true in all that I do. Accountable together – We are Purdue.”

Signature: _____

PROBLEM #1 (25 points)

Rigid bracket CAD is supported by elastic rods (1) and (2). A force P is applied downward at point B. Simultaneously, the temperature of rod (2) is changed by an amount ΔT . The temperature of rod (1) is kept constant. The geometry and material properties of rods (1) and (2) are listed in the following table:

	Cross-sectional area	Length	Young's modulus	Coefficient of thermal expansion
Rod (1)	A	L	$2E$	α
Rod (2)	A	$1.5L$	E	α

- (a) If the displacement of point C is known to be 10^{-4} in. downward, determine the axial force F_1 carried by rod (1), the axial force F_2 carried by rod (2), and the applied force P .
- (b) Using the forces determined in part (a), determine the factor of safety guarding against yielding of pin A if the pin has a cross-sectional area of 0.1 in^2 , shear yield strength $\tau_Y = 20 \text{ ksi}$, and is connected to the ground by a double-sided connection as shown in Figure 1.b.

Use the following numerical values: $E = 30 \times 10^3 \text{ ksi}$, $\alpha = 10^{-6} / ^\circ\text{F}$, $L = 10 \text{ in}$, $A = 2 \text{ in}^2$, $\Delta T = -20 ^\circ\text{F}$ (i.e. the temperature of rod (2) is decreased)

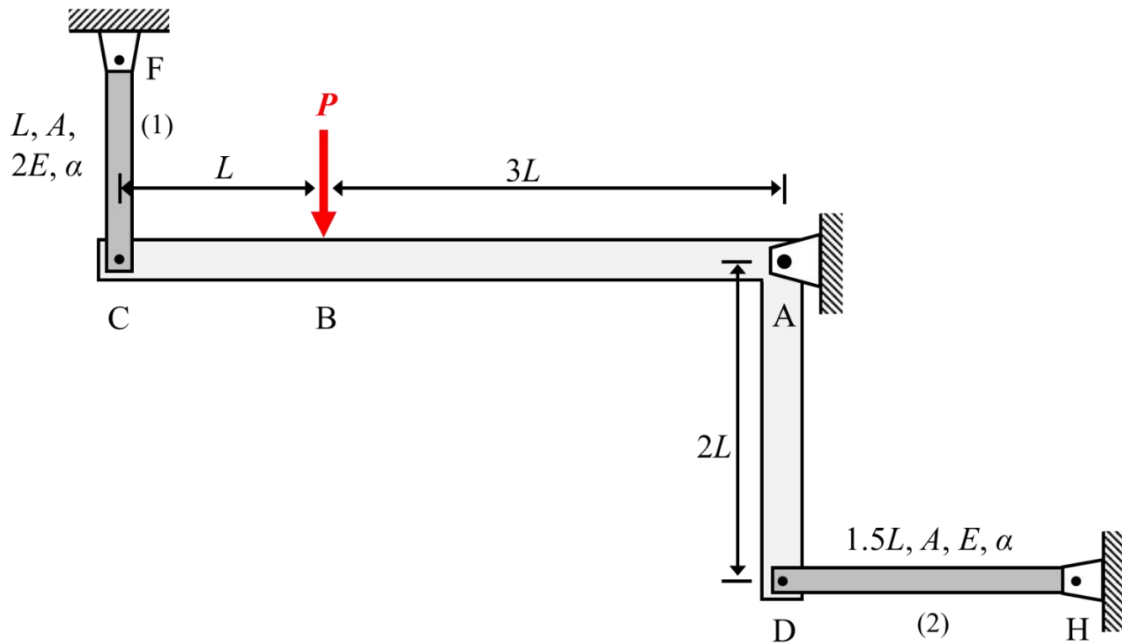

Figure 1.a.

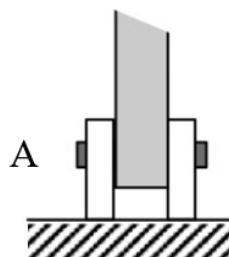

Figure 1.b: Edge view of the pinned connection at A.

ME 323 Examination # 1

Name _____
(Print) **(Last)** **(First)**

ME 323 Examination # 1

Name _____
(Print) **(Last)** **(First)**

PROBLEM #2 (25 points)

A simply supported beam ABCD is subject to a distributed load that varies from 0 to $w = 4 \text{ kN/m}$ in section AB. Additionally, a point load $P = 5 \text{ kN}$ is applied at D and moment $M = 6 \text{ kN m}$ is applied at C. Construct the shear force and bending moment diagrams for the beam. Mark the critical values of the shear and bending moment on the diagrams.

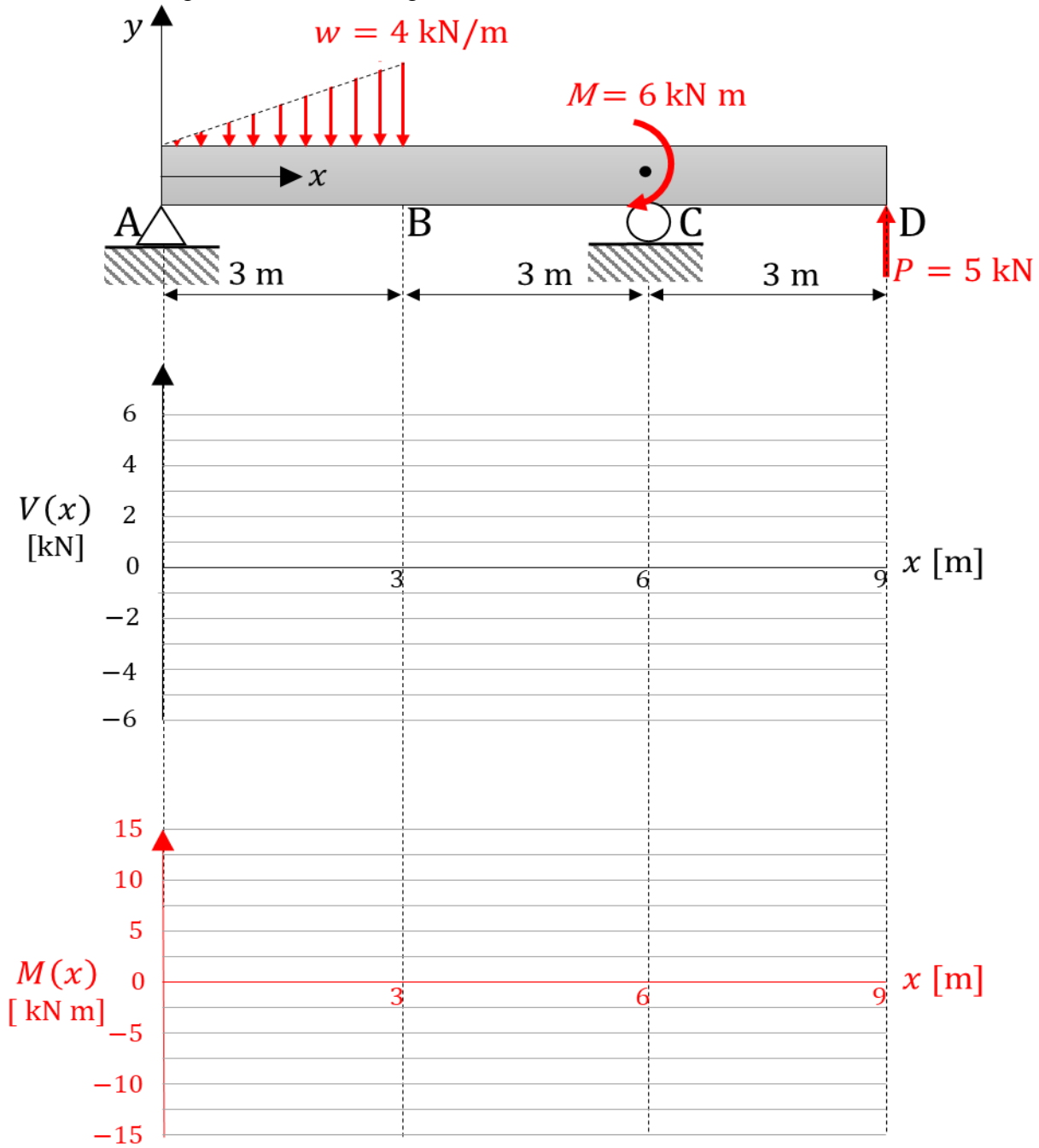

Figure 2

ME 323 Examination # 1

Name _____
(Print) **(Last)** **(First)**

ME 323 Examination # 1

Name _____
(Print) **(Last)** **(First)**

PROBLEM #3 (25 points)

A torque T is applied to a gear-shaft system and is transmitted through rigid gears B and C to a fixed end E as shown in Fig. 3(a). The shafts (1) and (2) are tightly fit to each other. Frictionless bearings are used to support the shafts. The geometry and material property of the shafts and gears are listed in the following table.

	Size	Length	Shear modulus
Shaft (1)	Outer diameter = $2d$ Inner diameter = d	L	$2G$
Shaft (2)	Diameter = d	L	G
Shaft (3)	Diameter = d	$L/2$	G
Shaft (4)	Diameter = d	L	G
Gear B	Diameter = $1.5d$	Negligible	Rigid
Gear C	Diameter = $3d$	Negligible	Rigid

- Determine the torque carried by each shaft.
- Determine the angle of twist at the free ends A and D.
- Consider the cross section aa' for the shafts (1) and (2), show the magnitude of the shear stress as a function of the distance from the center on Fig. 3(b). Mark the critical values in the diagram.
- Consider the points M and N on the cross section aa' , shown in Fig. 3(c). Sketch the stress states at M and N on the stress elements on Fig. 3(d).

Express all your answers in terms of d, L, G, T, π .

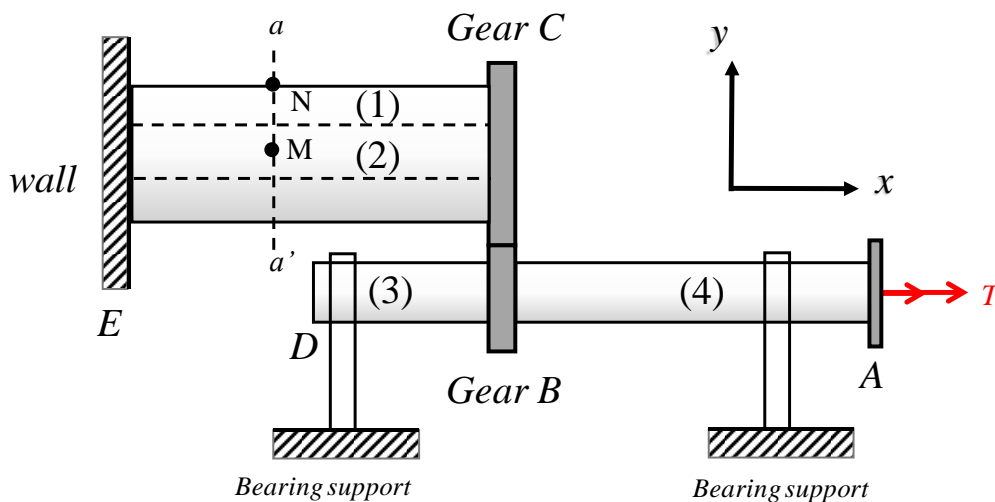

Fig. 3(a)

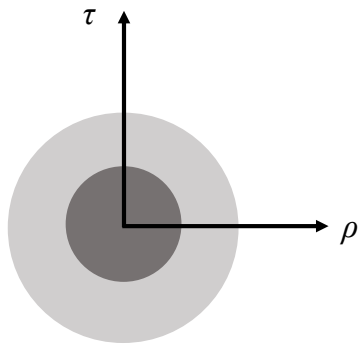

Fig. 3(b)

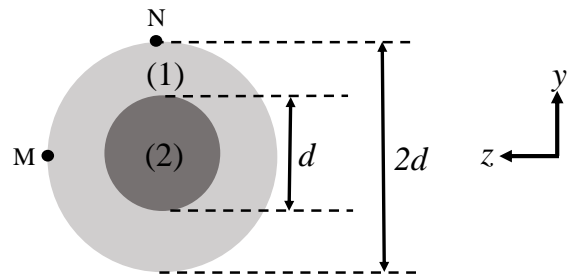

Fig. 3(c)

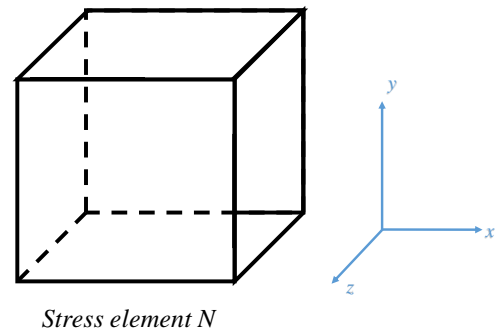
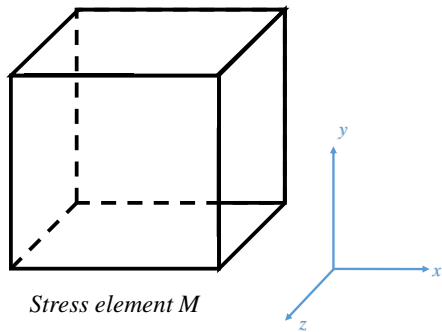

Fig. 3(d)

ME 323 Examination # 1

Name _____
(Print) **(Last)** **(First)**

ME 323 Examination # 1

Name _____
(Print) **(Last)** **(First)**

PROBLEM #4 (25 Points):

PART A – 6 points

For each state of plane stress shown below, i.e., for configurations (a) and (b), indicate whether each component of the state of strain is:

- ❖ = 0 (equal to zero)
- ❖ > 0 (greater than zero)
- ❖ < 0 (less than zero)

The material is linear elastic with Poisson’s ratio ν ($0 < \nu < 0.5$), and the deformations are small.

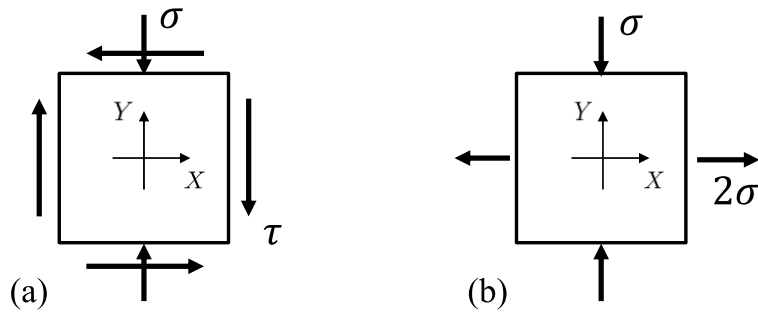

	(a)	(b)
ϵ_x		
ϵ_y		
ϵ_z		
γ_{xy}		
γ_{xz}		
γ_{yz}		

Fill in with ‘= 0’, ‘> 0’, or ‘< 0’.

PROBLEM #4 (cont.):**PART B – 4 points**

A rod is made up of elastic elements 1 and 2, each having a length L and cross-sectional area A . Elements 1 and 2 have the same Young's modulus $E_1=E_2$ and coefficient of thermal expansion $\alpha_1=\alpha_2$. Let F_1 and F_2 represent the axial load carried by elements 1 and 2, respectively, when the temperature of element 1 is increased by $\Delta T_1 > 0$ — while the temperature of element 2 is kept constant $\Delta T_2 = 0$.

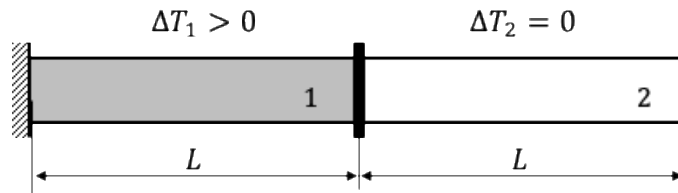

Circle the correct answer:

- a) $|e_1| > |e_2|$
- b) $|e_1| = |e_2|$
- c) $|e_1| < |e_2|$

Circle the correct answer:

- a) $|F_1| > |F_2|$
- b) $|F_1| = |F_2|$
- c) $|F_1| < |F_2|$

Circle the correct answer:

- a) Elastic element 1 is under tension
- b) Elastic element 1 is under compression
- c) Elastic element 1 is stress-free

Circle the correct answer:

- a) Elastic element 2 is under tension
- b) Elastic element 2 is under compression
- c) Elastic element 2 is stress-free

PROBLEM #4 (cont.):**PART C – 4 points**

A rod is made up of elastic elements 1 and 2, each having a length L and cross-sectional area A . Elements 1 and 2 have the same Young's modulus $E_1=E_2$ and coefficient of thermal expansion $\alpha_1=\alpha_2$. Let F_1 and F_2 represent the axial load carried by elements 1 and 2, respectively, when the temperature of element 1 is increased by $\Delta T_1 > 0$ — while the temperature of element 2 is kept constant $\Delta T_2 = 0$.

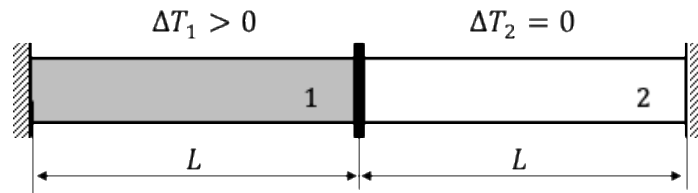

Circle the correct answer:

- a) $|e_1| > |e_2|$
- b) $|e_1| = |e_2|$
- c) $|e_1| < |e_2|$

Circle the correct answer:

- a) $|F_1| > |F_2|$
- b) $|F_1| = |F_2|$
- c) $|F_1| < |F_2|$

Circle the correct answer:

- a) *Elastic element 1 is under tension*
- b) *Elastic element 1 is under compression*
- c) *Elastic element 1 is stress-free*

Circle the correct answer:

- a) *Elastic element 2 is under tension*
- b) *Elastic element 2 is under compression*
- c) *Elastic element 2 is stress-free*

PROBLEM #4 (cont.):**PART D – 4 points**

A rod is made up of elastic elements 1 and 2, each having a length L and cross-sectional area A . Elements 1 and 2 have the same Young's modulus $E_1=E_2$ and coefficient of thermal expansion $\alpha_1=\alpha_2$. Let F_1 and F_2 represent the axial load carried by elements 1 and 2, respectively, when the temperature of element 1 is increased by $\Delta T_1 > 0$ — while the temperature of element 2 is kept constant $\Delta T_2 = 0$.

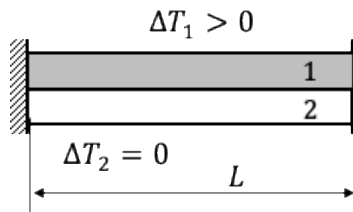

Circle the correct answer:

- a) $|e_1| > |e_2|$
- b) $|e_1| = |e_2|$
- c) $|e_1| < |e_2|$

Circle the correct answer:

- a) $|F_1| > |F_2|$
- b) $|F_1| = |F_2|$
- c) $|F_1| < |F_2|$

Circle the correct answer:

- a) *Elastic element 1 is under tension*
- b) *Elastic element 1 is under compression*
- c) *Elastic element 1 is stress-free*

Circle the correct answer:

- a) *Elastic element 2 is under tension*
- b) *Elastic element 2 is under compression*
- c) *Elastic element 2 is stress-free*

PROBLEM # 4 (cont.):

PART E – 7 points

Use only the compatibility condition for the truss structure shown in the figure to find the value of the elongation of member 1 (e_1) in terms of the elongation of member 2 (e_2) and the elongation of member 3 (e_3).

- a) Determine an expression for the **compatibility condition** at A:

$$e_1 = a e_2 + b e_3$$

where a and b are numbers.

Note: Please notice that you are not required to solve for the internal axial forces at equilibrium.

- b) Circle the correct answer.

TRUE or **FALSE**: The elongation of element 1 depends on the material makeup of elements 2 and 3.

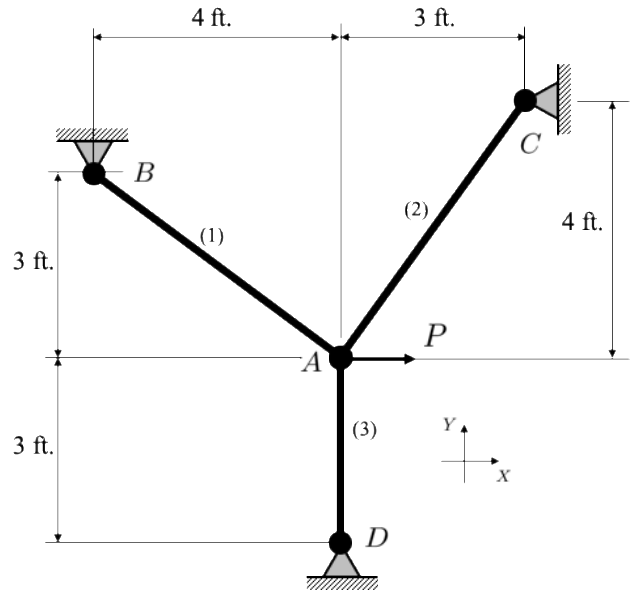

ME 323 Examination # 1

Name _____
(Print) **(Last)** **(First)**