

Name (Print) _____
(Last) (First)

**ME 323 - Mechanics of Materials
Final Exam**

Date: December 9, 2019, Time: 3:30 – 5:30 PM

Instructions:

Circle your instructor's name and your class meeting time.

Gonzalez	Kokini	Zhao	Pribe
11:30-12:20PM	12:30-1:20PM	2:30-3:20PM	4:30-5:20PM

The only authorized exam calculator is the TI-30XIIS or the TI-30Xa.

Begin each problem in the space provided on the examination sheets.

Work on **ONE SIDE** of each sheet only, with only one problem on a sheet.

Please remember that for you to obtain maximum credit for a problem, you must present your solution clearly. Accordingly,

- coordinate systems must be clearly identified,
- free body diagrams must be shown,
- units must be stated,
- write down clarifying remarks,
- state your assumptions, etc.

If your solution cannot be followed, **it will be assumed that it is in error.**

When handing in the test, make sure that ALL SHEETS are in the correct sequential order.

Please review and sign the following statement:

Purdue Honor Pledge – “As a Boilermaker pursuing academic excellence, I pledge to be honest and true in all that I do. Accountable together – We are Purdue.”

Signature: _____

PROBLEM #1 (25 Points):

Two elastic elements (1) and (2) are connected to the ends A and B of a rigid inverted T-shaped bar ABCD. Each elastic member has a Young’s modulus E , circular cross section of radius R , length L , and yield stress σ_Y . The rigid bar is pinned at C and a load P is applied at end D, as shown in Figure 1.

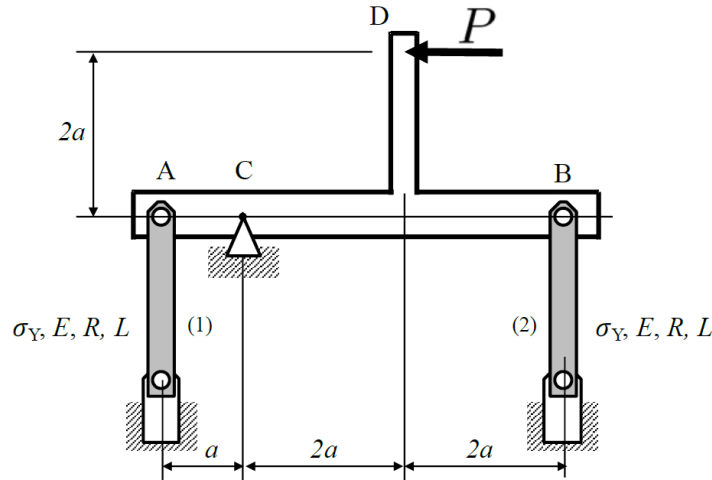

Figure 1

- (a) Assuming both elastic elements are under tension, draw a free body diagram of the rigid T-shaped bar.
- (b) Write the equilibrium equations for the rigid T-shaped bar and the compatibility condition(s) that relate the elongation of the elastic elements (1) and (2).
- (c) Determine the axial force on elastic elements (1) and (2) and, for $P > 0$, indicate whether the element is under compression or tension.
- (d) Determine the smallest force $P > 0$ ((i.e., the smallest force P in the direction shown in the figure)) that will induce *Euler buckling* on the assembly and indicate whether it will be on element (1) or (2). Express your result in terms of material properties and geometric parameters.
- (e) If the slenderness of elements (1) and (2) is significantly reduced to avoid buckling, then determine the smallest force $P > 0$ that will induce *ductile failure* on the assembly and indicate whether it will be on element (1) or (2). Express your result in terms of material properties and geometric parameters.

Note: Use the maximum-distortional-energy theory.

ME 323 Final Exam

Name _____
(Print) **(Last)** **(First)**

ME 323 Final Exam

Name _____
(Print) **(Last)** **(First)**

PROBLEM #2 (25 points)

An angled wrench ABC is fixed to the ground at A. The wrench is aligned along the xz plane as shown in the Figure 2A, such that the AB is along the x axis and BC is along the z axis. Two point-forces of the same magnitude P , **one in the negative x direction and the other in the positive y direction**, are applied at the end C. The segment AB has a circular cross section of the radius r as shown in Figure 2B. The length of AB and BC are a and b , respectively.

- Determine the resultant load (forces and moments) on the cross section at the ground due to the applied forces at C.
- Determine the state of stress at point M located on the cross section at the ground. Show the non-zero stresses on the given stress element.
- Determine the state of stress at point N located on the cross section at the ground. Show the non-zero stresses on the given stress element.

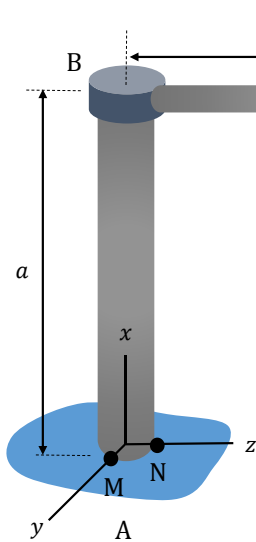

Figure 2A

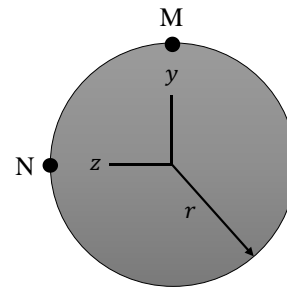

Figure 2B

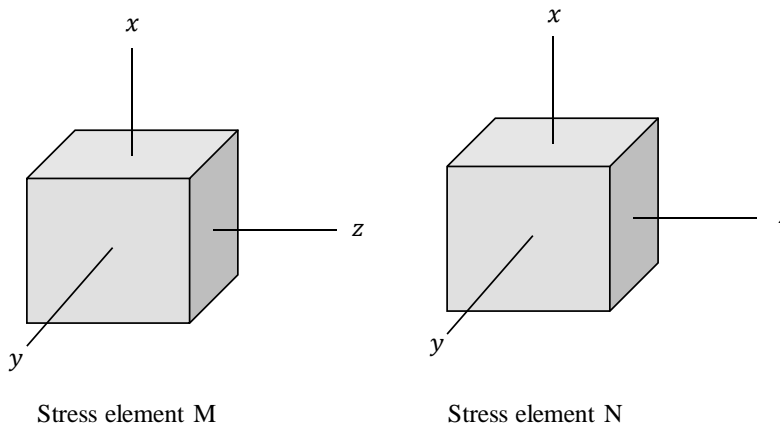

Figure 2C

Name _____
(Print) **(Last)** **(First)**

ME 323 Final Exam

Name _____
(Print) **(Last)** **(First)**

PROBLEM #3 (25 points)

A point A on the structure in Figure 3A is subjected to in-plane stresses as shown in Figure 3B.

- (a) Use the stress element in Figure 3B to draw the **Mohr's circle** on the attached graph paper.
- (b) Use the **Mohr's circle** to calculate:
 - i. The principal stresses in the X-Y plane.
 - ii. The maximum in-plane shear stress.
 - iii. The absolute maximum shear stress.
 - iv. The angle of rotation from the X-axis to the direction of the in-plane principal stress σ_{p1} .
 - v. Draw a stress element to show the in-plane principal stresses correctly oriented with respect to the X axis
- (c) Determine the normal and shear stresses in the X'-Y' directions, draw a stress element to show the calculated stresses, and mark the state of stress in the X'-Y' directions on the Mohr's circle. Note: The X' axis is oriented at 45° from the X axis as shown in Figure 3A.

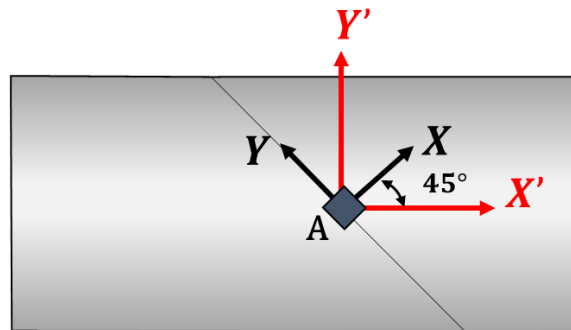

Figure 3A: Structure with element A

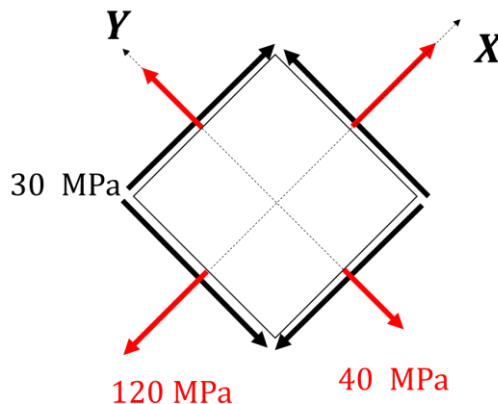
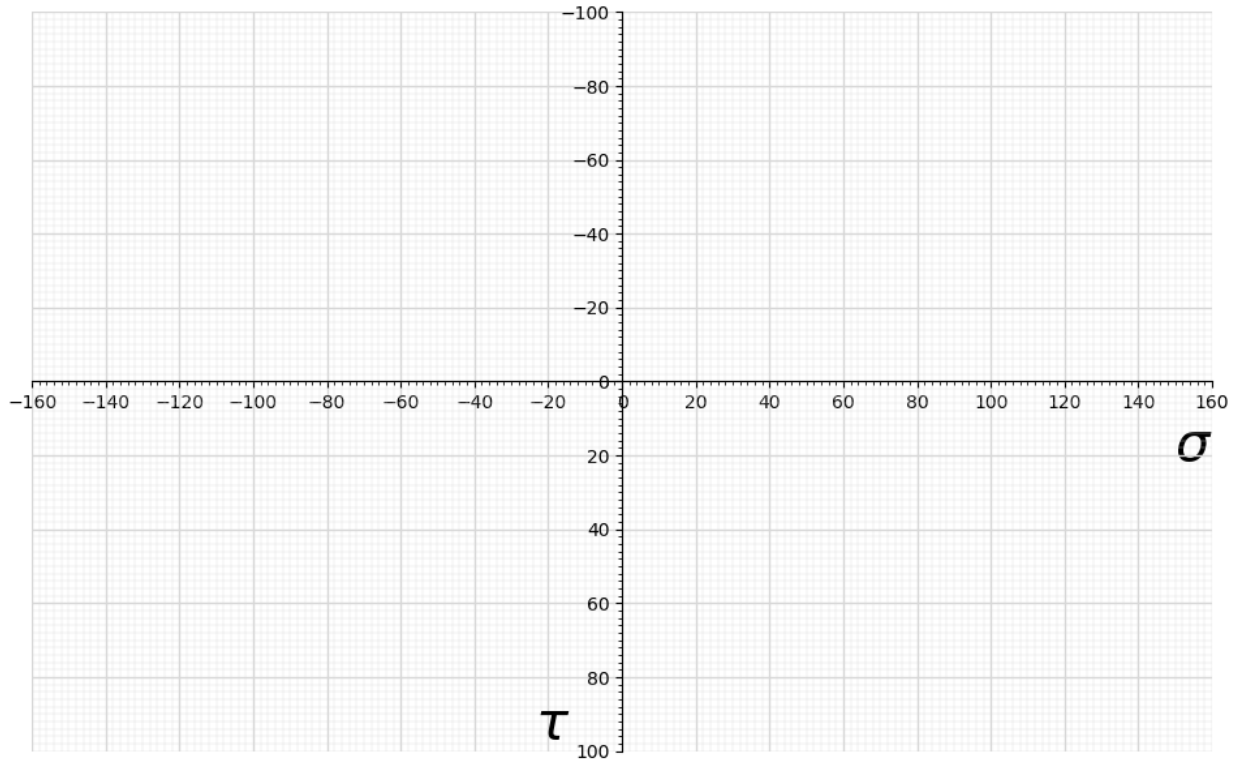

Figure 3B: Stress element A



Name _____
(Print) **(Last)** **(First)**

Name _____
(Print) **(Last)** **(First)**

PROBLEM #4 (25 Points):

PART A – 5 points

(i) For the state of stress shown below, $\sigma_x = \sigma_y = 0$ and $\tau_{xy} = \tau$. Let τ_{MSS} and τ_{MDE} be the values of τ required to cause yielding based on the maximum shear stress and maximum distortional energy theories, respectively. The yield strength of the ductile material is σ_Y .

Circle the answer that best describes the relative sizes of τ_{MSS} and τ_{MDE} .

- (a) $\tau_{MSS} > \tau_{MDE}$
- (b) $\tau_{MSS} = \tau_{MDE}$
- (c) $\tau_{MSS} < \tau_{MDE}$

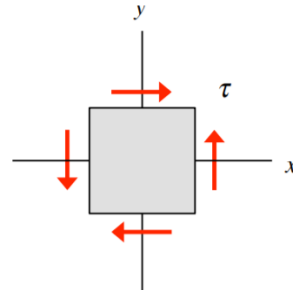

(ii) The beam shown below has a square cross section and is made of a brittle material where the ultimate compressive strength is **larger** than the ultimate tensile strength. The beam is subjected to a bending moment $M > 0$ as shown below. Let M_a and M_b be the values of the bending moment required to cause brittle failure at points a and b , respectively, based on **Mohr's failure criterion**.

Circle the answer that best describes the relative sizes of M_a and M_b .

- (a) $M_a > M_b$
- (b) $M_a = M_b$
- (c) $M_a < M_b$

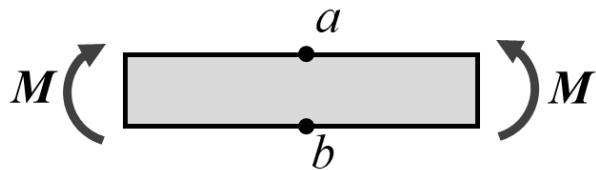

ME 323 Final Exam

Name _____
(Print) **(Last)** **(First)**

PROBLEM #4 (cont.):

PART B – 10 points

Questions (i) and (ii) in Part B refer to the eight Mohr's circles shown below.

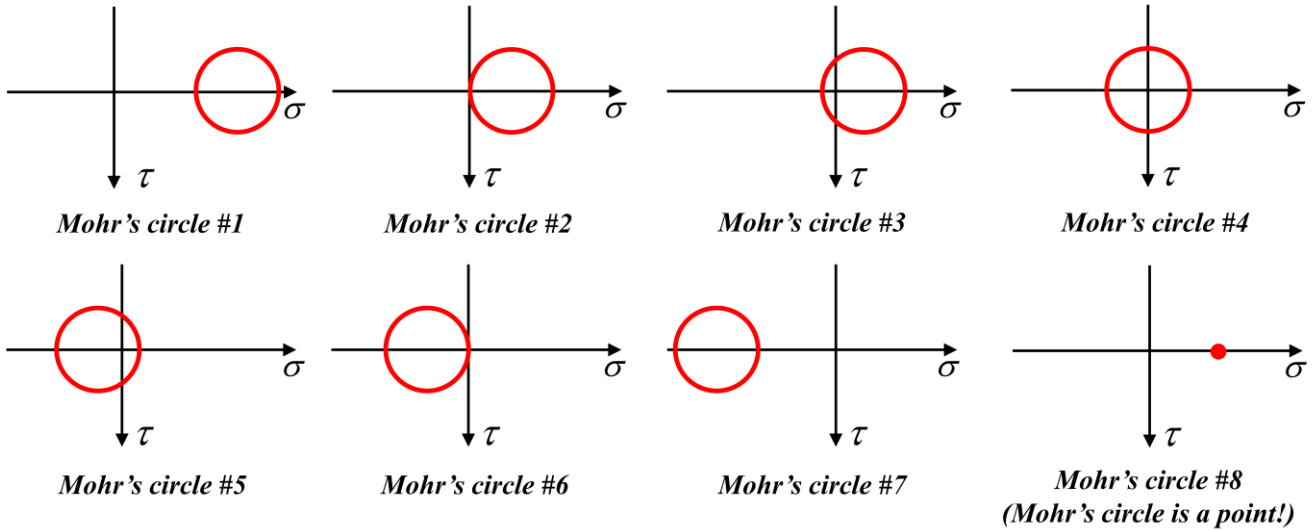

(i) The cylindrical and spherical thin-walled pressure vessels are each subjected to an internal pressure. Point *a* is on the surface of the cylindrical pressure vessel. Point *b* is on the surface of the spherical pressure vessel.

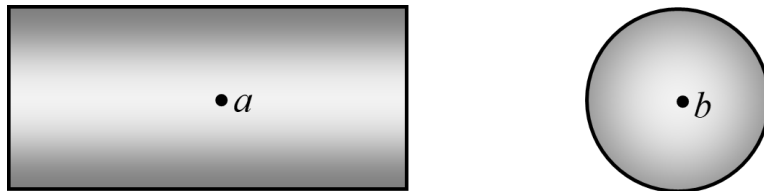

Circle the number of the **correct in-plane Mohr's circle** for the state of stress at:

- Point *a*: #1 #2 #3 #4 #5 #6 #7 #8
- Point *b*: #1 #2 #3 #4 #5 #6 #7 #8

PROBLEM #4 (cont.):

PART B (cont.)

(ii) At a cut in the circular rod shown below, the internal resultant loads are determined to be a bending moment M about the negative z -axis and a torque T about the positive x -axis.

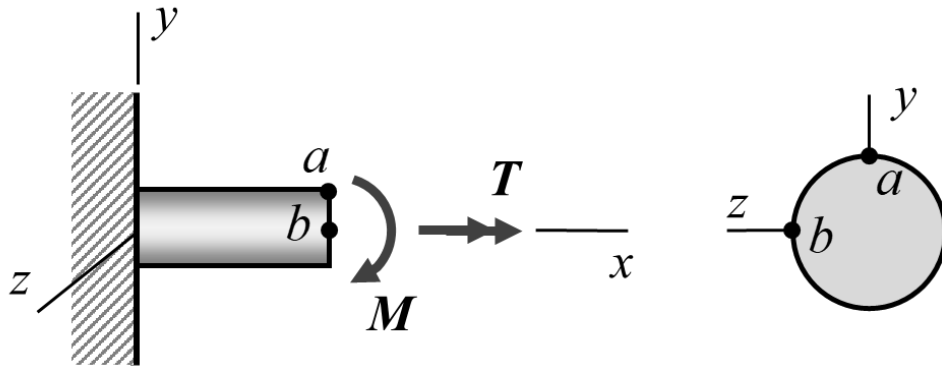

Circle the number of the **correct in-plane Mohr's circle** for the state of stress at:

- Point a : #1 #2 #3 #4 #5 #6 #7 #8
- Point b : #1 #2 #3 #4 #5 #6 #7 #8

PART C – 6 points

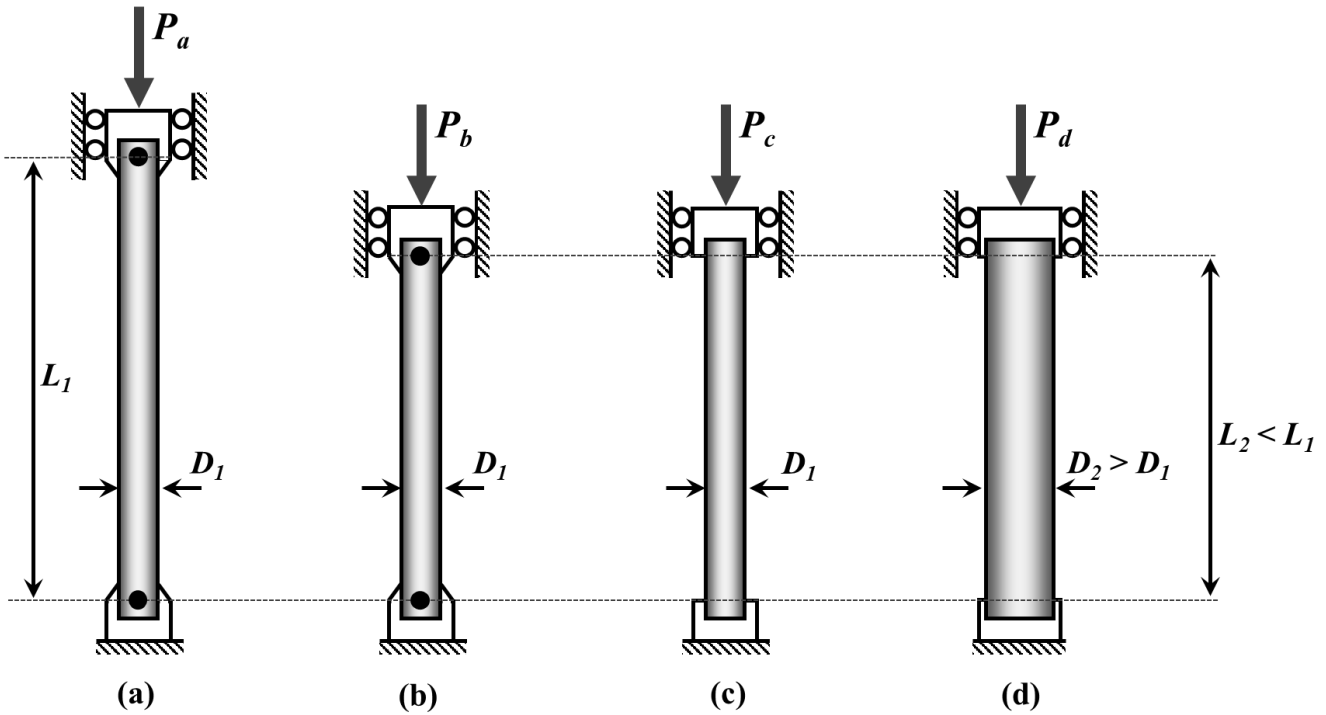

Solid cylindrical columns (a), (b), (c), and (d) are made of the same material with Young’s modulus E . A compressive axial load is applied to each column. Let $P_{a,cr}$, $P_{b,cr}$, $P_{c,cr}$, and $P_{d,cr}$ represent the critical buckling loads for columns (a), (b), (c), and (d), respectively, according to Euler’s buckling theory.

Rank order the critical buckling loads for each column from 1 to 4, where 1 represents the *largest* critical buckling load, and 4 represents the *smallest* critical buckling load, on the lines below.

$P_{a,cr}$ _____

$P_{b,cr}$ _____

$P_{c,cr}$ _____

$P_{d,cr}$ _____

PROBLEM #4 (cont.):

PART D – 4 points

A cantilevered beam is loaded with a force P , a distributed load p_0 , and a moment M .

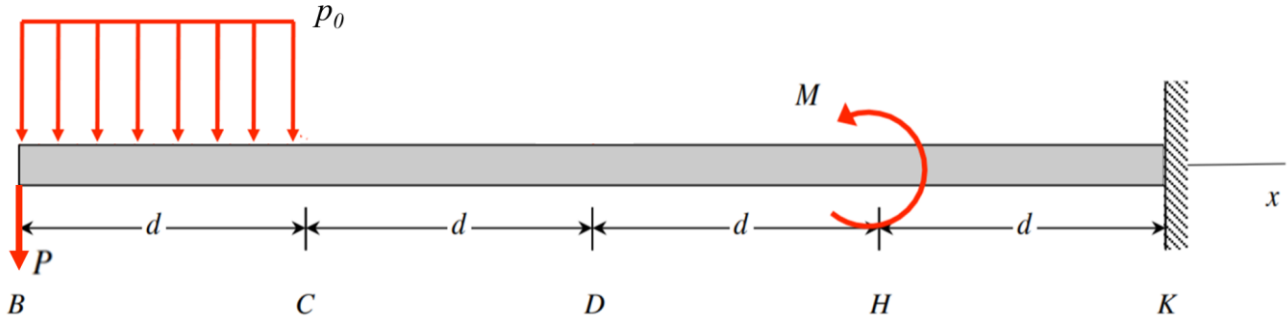

(i) Circle the answer that most accurately describes the internal **shear force** between points B and C.

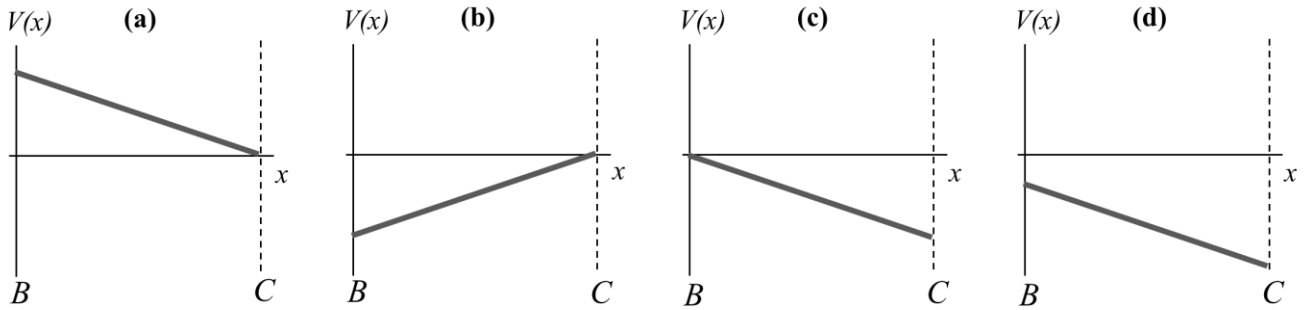

(ii) Circle the answer that most accurately describes the internal **bending moment** between points B and C.

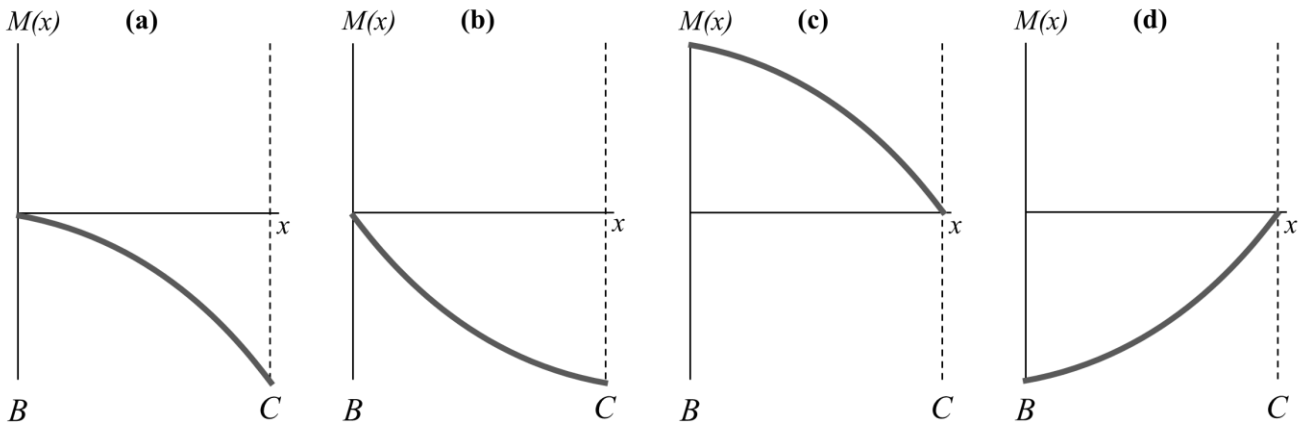

Name _____
(Print) **(Last)** **(First)**